

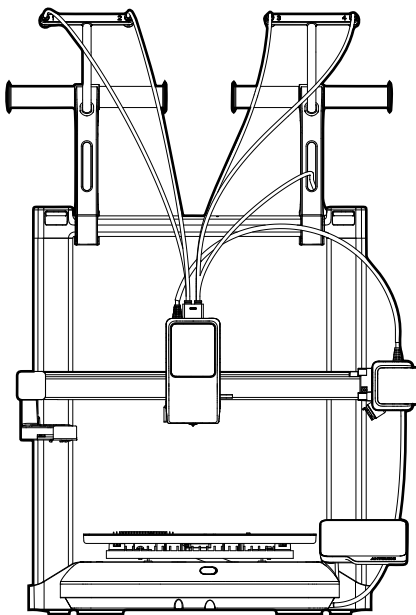

Anycubic Kobra X User Manual



Support Center
(Including installation video
and slicing software installation)

The pictures are for reference only,
please refer to the actual product.

Thank you for choosing **ANYCUBIC** !

If you've previously purchased an **ANYCUBIC** machine or are familiar with 3D printing technology, we still recommend that you carefully read the precautions and usage tips in this manual to avoid incorrect installation and use. If you encounter questions or issues not covered in this manual, please visit the **ANYCUBIC** official website for more help and support related to this product.
(<https://cn.anycubic.com>)

To better experience our products, you can also obtain machine operating information through the following methods:

1. For more help and support related to this product, please scan the QR code "ANYCUBIC Wiki".
2. Our WeChat official account will regularly publish the latest 3D printing industry trends, cutting-edge technical information, and common technical guides.



ANYCUBIC
Slicer



ANYCUBIC Wiki



ANYCUBIC
Official Website



WeChat
Official Account

*The copyright of this manual belongs to Shenzhen Zongwei Cube Technology Co., Ltd. Any reproduction without permission is prohibited.

ANYCUBIC Team

Table Of Contents

1 Product Introduction 1

2 Product Installation 3

Install the Printing Plate 3

Unlock the Gantry Z Axis 4

Installing the Gantry Frame 5

Connect the Printhead, Camera
and XZ Axis Motor Cables 6

Install the Purge Wiper 7

Install the Spool Holder 8

Install Teflon Tube 9

3 Power on 10

4 Bind Printer 12

APP 12

Slicer 13

5 Machine maintenance 16

6 Precautions 17

Products at a Glance

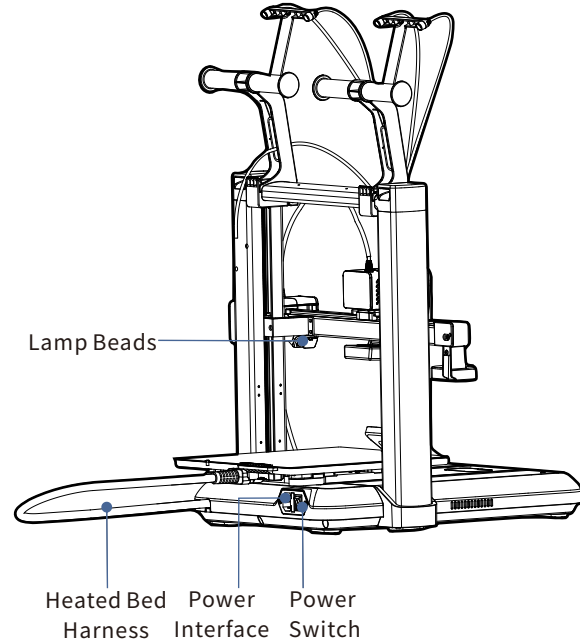
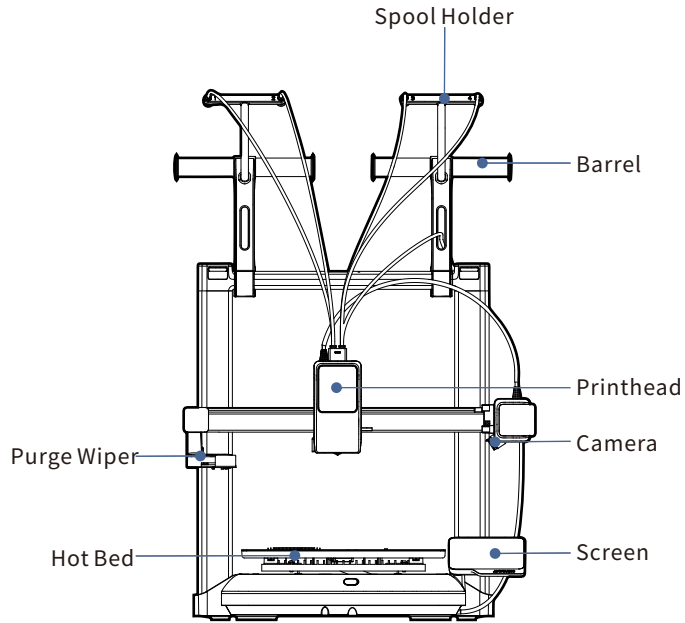

Packing List

Note: The following pictures are for reference only.
Please refer to the actual product received.

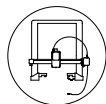

Gantry Frame

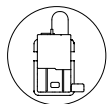

Printer Base



Power Cord

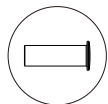

Barrel
(4pcs)

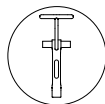

Spool Holder
(2pcs)

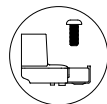

Purge Wiper
&M3*8(1pcs)

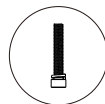

M5*30(8pcs)



Cable Clip

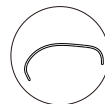

Teflon Tube
(4pcs)



Filament Samples



Grease



Nozzle Cleaner



4.0/2.5/2.0
&Magnet



Decorative Cover
(2pcs)

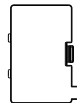

Cable Cover



Printing Board



Application
Brush

Specifications

Printer parameters

Printing Principle:FDM (Fused Deposition Modeling)
Print volume:260 mm (L) × 260 mm (W) × 260mm (H)
Print layer thickness:0.08 - 0.28 mm
Hot bed temperature:100°C
Number of nozzles:Single nozzle
Nozzle diameter:0.4 mm
Consumables:PLA/TPU/PETG/ABS etc.

Software parameters

Slicer:AC Slicer/PrusaSlicer/Cura
Input format:.STL, .OBJ
Output format:GCode
Connection method:Anycubic APP,Anycubic Slicer

Power supply parameters

Power input:110V~,60Hz
Rated power:1450W

WIFI

Frequency band:2.4GHz,5GHz
Working Mode:STA, AP+STA Blending Mode

Physical parameters

Machine size:441.5mm (L) × 448.8mm (W) × 451.3 mm (H)
Maximum size of the machine
(including Spool Holder and hot bed moving forward and backward):
450mm (L) × 540mm (W) × 680 mm (H)
Machine net weight:9.5kg

Product Installation

Please scan the QR code on the right for the installation instruction video:



1 Install the Printing Plate

1. Remove the print plate and printer base.
2. Install the print plate with the front (with silkscreen printing) facing up, aligning the edges of the print plate with the edges of the heated bed.

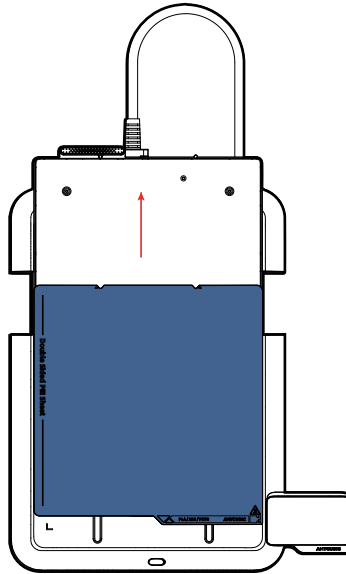

② Unlock the Gantry Z Axis

1、Use an H2.0 hexagonal wrench to loosen the six screws on the gantry frame's Z-axis fixture (three on each side, the same procedure applies).

*Tip: In any installation process that uses a hex wrench, you can attach a magnet to the wrench to magnetize it. You can also move the magnet closer to the working end of the wrench to increase the strength of the magnet.

Note: To avoid damaging the machine, it is strictly forbidden to power the machine before unlocking the Z-axis.

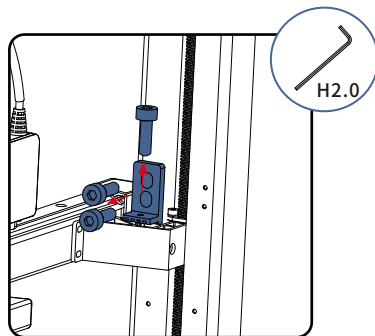
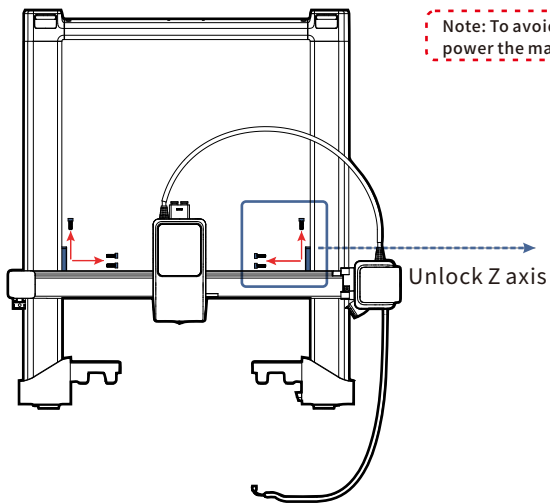

③ Install the Gantry Frame

1. Grab the top horizontal axis of the gantry and lift the X-axis to 3/4 the height of the Z-axis for subsequent installation;
2. Push the printer base heated bed to the front to expose the screw positions between the base and the gantry frame;
3. Use an H4.0 hexagonal wrench to tighten the M5*30 screws (eight in total, four on each side) between the printer base and the gantry frame from top to bottom;
4. Replace the decorative cover (press down to secure).

Note: It is recommended to hold the long end of the hexagonal wrench for secondary tightening.

① Raise the Z axis

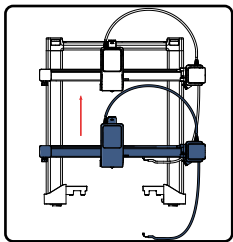

② Reveal locked position

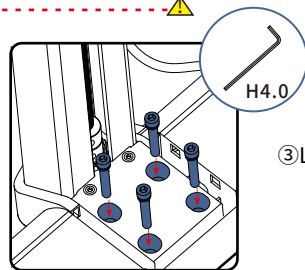
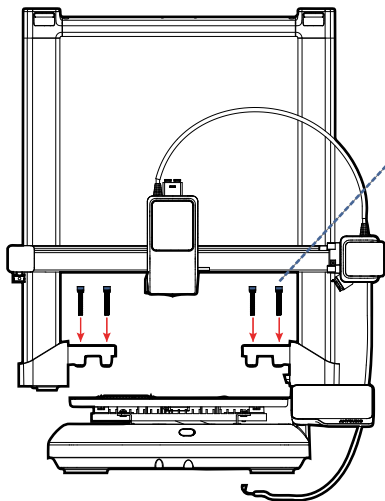
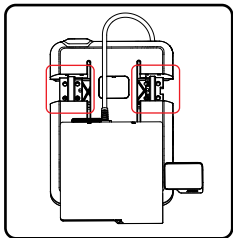

③ Locking screw

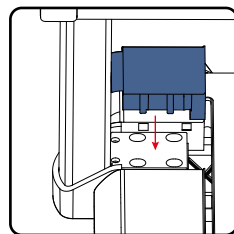

④ Put on the decorative cover

4 Connect the Printhead, Camera and XZ Axis Motor Cables

1. Tilt the printer backward to expose the bottom of the printer base;
2. Insert one end of the single-plug cable into the Z-axis interface on the machine base, and the other end into the interface on the bottom right side of the gantry frame. For the three-plug cable, insert it into the X-axis, Printhead, and CAM interfaces in descending order of the number of pins, and secure the cables into their respective slots;
3. Replace the cable cover.

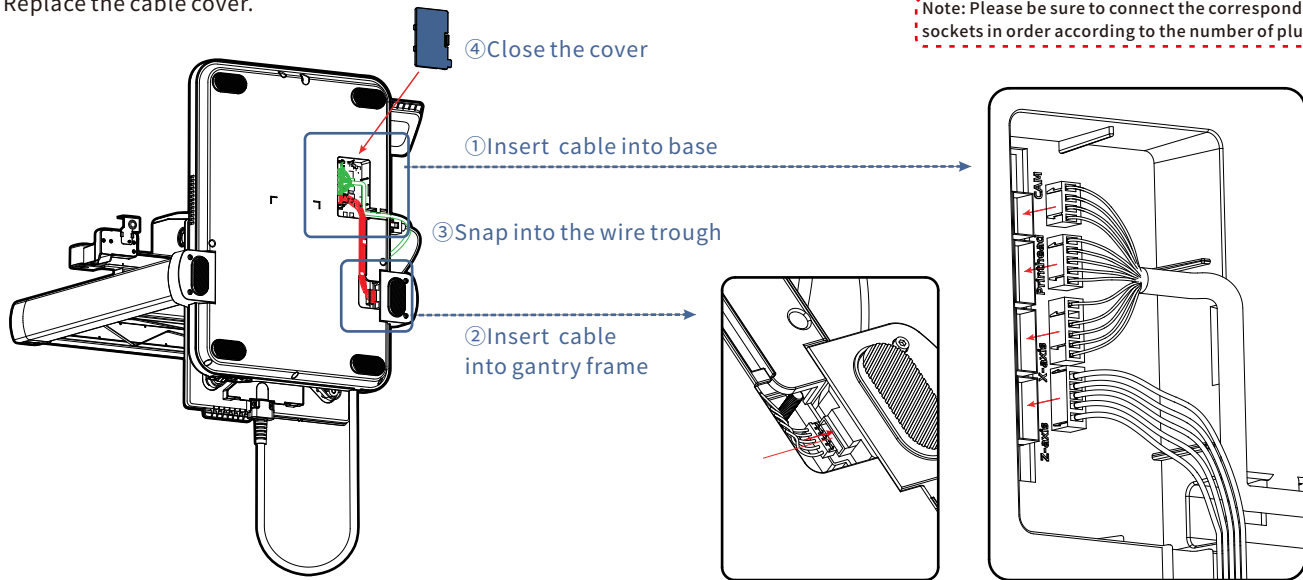

5 Install the Purge Wiper

1. Push the Purge Wiper from the front to the back into the left side of the machine.
2. Use an H2.0 hexagonal wrench to tighten the M3*8(Inside the transparent bag for the material handling assembly) self-tapping screw from the back of the Purge Wiper.

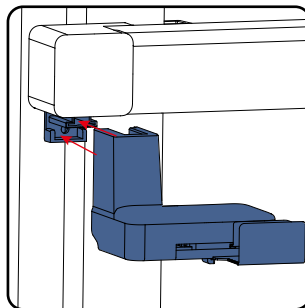
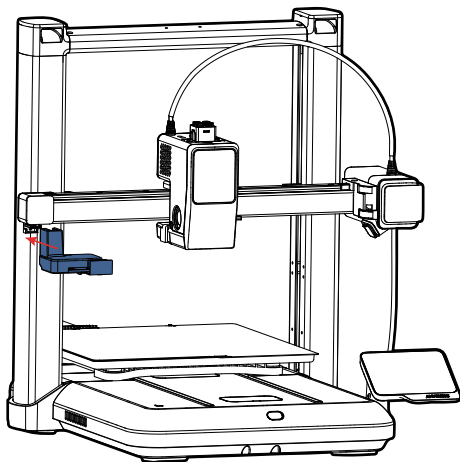

① Insert into the slide

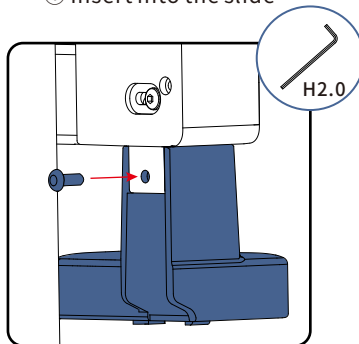

② Locking screw

6 Install the Spool Holder

1. Assemble the two filament racks in sequence: Insert the support rods into the left and right sides of the spool holder, rotate and push until they are fully seated, then rotate downward and lock them securely.
2. Once the spool holder are assembled, snap them into place on the left and right sides of the horizontal axis at the top of the gantry.

Note: To facilitate material replacement, please move the spool holder to the left or right of the horizontal axis.

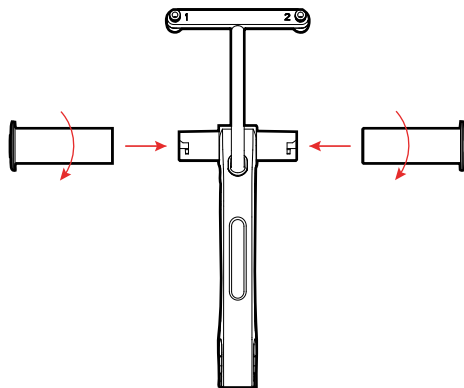

① Assemble the Spool Holder

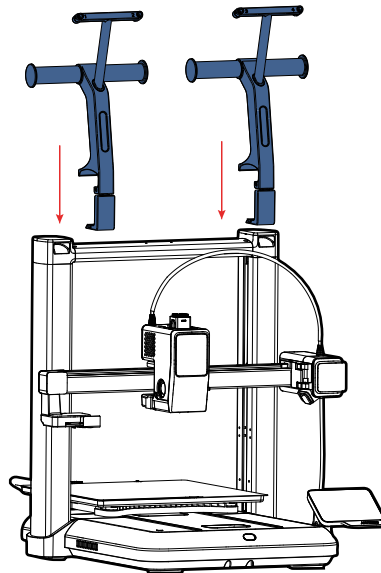

② Install the Spool Holder

7 Install Teflon Tube

Insert one end of each of the four Teflon tubes into the holes above the printhead, and the other ends into the feed ports on the front of the spool holders. (After completing all the above operations, you can power the machine using the power cord.)

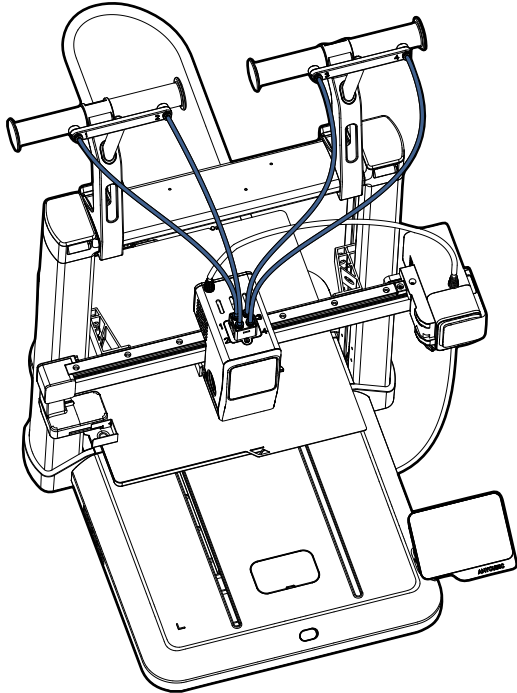

Note: Ensure each tube is connected to the correct port as per the markings 

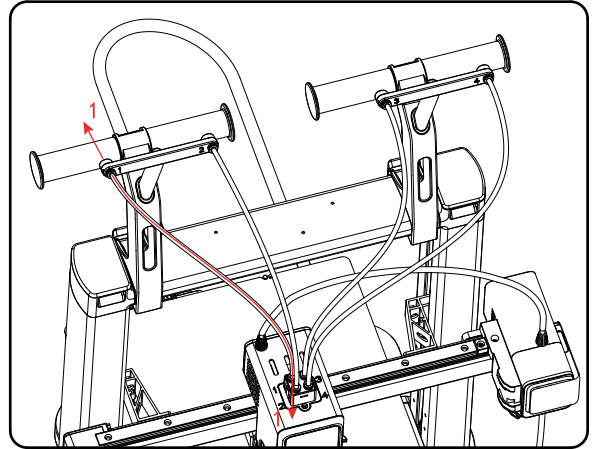

Power on

① Boot Page



② Language Selection

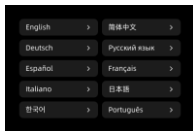

③ Region Selection

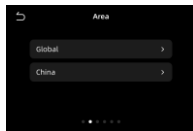

④ Network connection

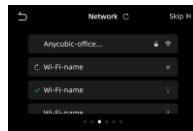

⑤ APP Download



⑥ Security Confirmation



⑦ Self-check
Reset to zero



⑧ Resonance
Compensation



⑨ Auto Leveling

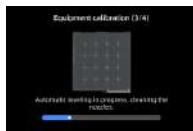

⑩ Active Noise
Cancellation



⑪ Calibration Complete



Makeronline QR code:
(Download the latest model
via Makeronline)



Note: The current interface is for reference only. Due to continuous feature upgrades, please refer to the interface released by the latest firmware for accurate information.



Load Filament

1. Place the filament on the spool holder (*It is recommended that the spool holder rotate in the same direction as the filament feeding, as shown in the picture below).
2. Insert the filament into the extruder. Successful filament feeding is indicated by the machine beeping and the screen displaying the filament material and color.

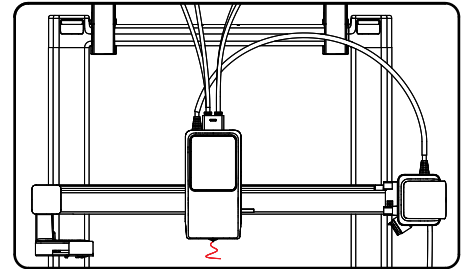
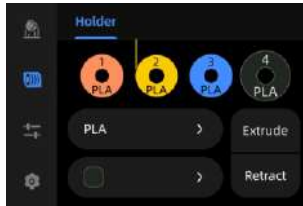
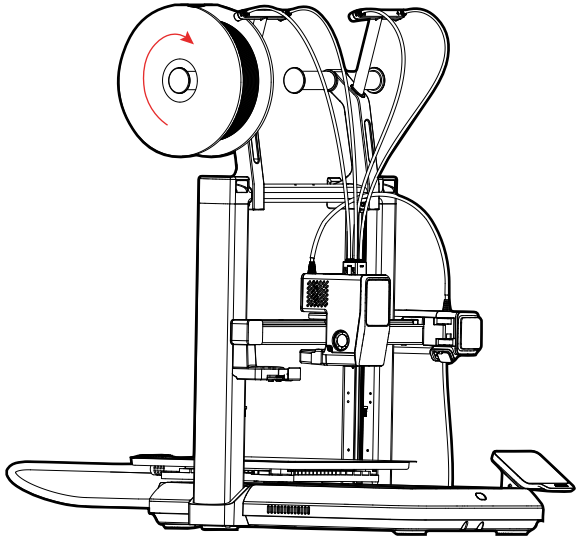

Add a Printer on the APP

1. Connect your printer to the internet.
2. Scan the QR code on the printer screen. Go to [Settings] - [Account]. Download the ANYCUBIC app, register, and log in to your ANYCUBIC account.
3. Open the ANYCUBIC app, tap "+Add Printer," and scan the QR code on the printer screen to link your ANYCUBIC account.

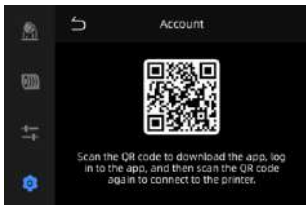

Slicer Installation and Printer Addition

1. Software installation: Follow the steps below.

Scan the QR code or visit: <https://www.anycubic.com/slicerNextDownload> to download and install the slicing software.

2. Please connect your printer to the internet before proceeding.

3. Slicing Software Usage Guide:

After software installation, access the main interface and click Workbench or Login to start remote printing.

① After the software is installed, go to the main page and click [Login/Register]. ② If you already have an account (synchronized with your mobile app account), you can directly enter your account and password to log in. If you don't have one, click [Sign up Now] to register.

Slicer download:

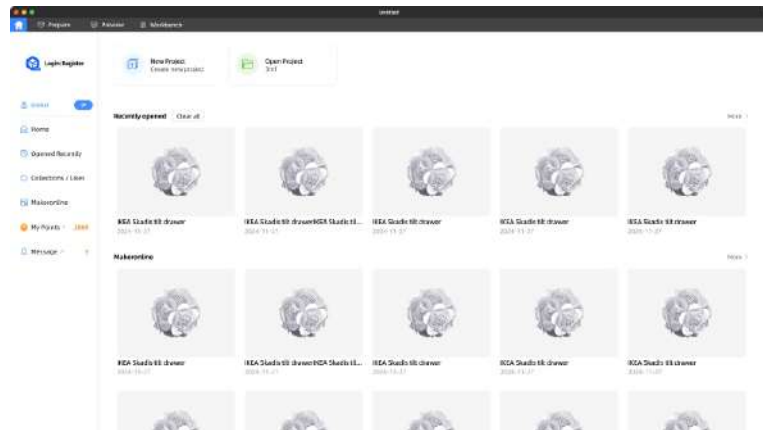

Note: The software interface is based on the latest version.

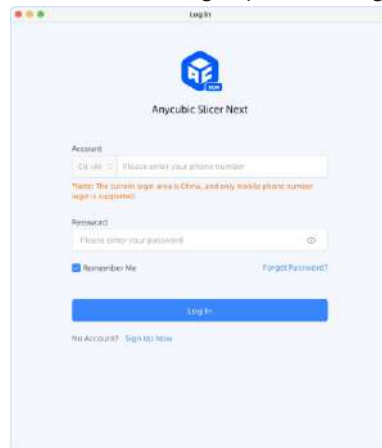

Slicer Installation and Printer Addition

③ Click [Workbench] and select [Add Printer].

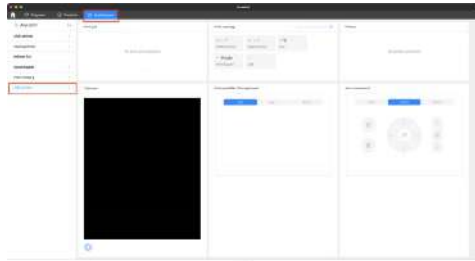

④ Automatically search for printers on the same local area network as your device and synchronize the printers linked to the app. If the printer you want to link to isn't found, click [Connect by CN Code].



⑤ How to find the CN code: On your printer, select [Settings > Device Information > Device CN Code]. You can view the CN code.



Upgrading the Firmware

Click [Settings] - [Printer Information] - [Firmware Version] - [Update] and wait for the machine to complete the firmware upgrade.

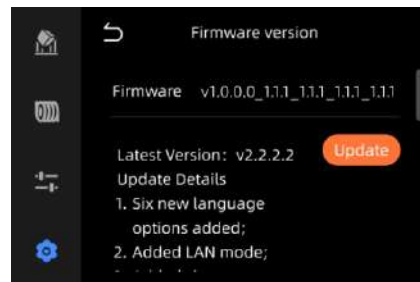

Machine Maintenance

3D printers are composed of complex mechanical structures and numerous moving parts. In order to ensure their stable operation and obtain high-quality printing results, regular maintenance and care are required.

Moving Metal Parts:

- Regularly lubricate the lead screw, linear rod, guide rail, idler pulley, and extruder wheel assembly to prevent rust.
- Lubricating oil can be used for the guide rail, linear rod, and idler pulley, while grease should be used for the lead screw and extruder wheel assembly.

Consumables:

- Regularly inspect plastic or rubber parts and cutter blades for signs of aging (including deformation) and damage.
- Replace parts such as silicone wipes and Teflon tubes as necessary.

Other Parts:

- Inspect the camera lens, fan, and filament sensor Hall effect components for debris or dust accumulation.
- Clean the fan with compressed air; gently wipe the camera with a lint-free cloth and isopropyl alcohol to ensure optimal cleanliness.

***We recommend using official Anycubic filaments. Anycubic has conducted extensive testing on these products to guarantee the best printing results.**



Scan the QR code to learn more about machine maintenance information

Precautions

- 1) The Anycubic 3D printer contains high-speed moving parts. Keep hands clear of moving parts to avoid injury.
- 2) If the machine is not in use for extended periods, please protect it from rain and moisture.
- 3) The Anycubic 3D printer generates high temperatures while in operation. Do not touch the working parts or the extruded material with your bare hands.
- 4) The nozzle of the machine can get very hot. Wear heat-resistant gloves when performing any operations to prevent burns.
- 5) In an emergency, immediately turn off the power to the Anycubic 3D printer.
- 6) Keep the Anycubic 3D printer and its accessories out of the reach of children.
- 7) When replacing the fuse, select a 250V, 10A fuse to avoid short circuits.
- 8) This device uses a removable plug. Unplug it if not in use for extended periods or if the power is off.
- 9) Minor scratches on the extrusion material or unevenness on the platform are normal as long as they do not affect normal printing.

*If you still have questions that cannot be resolved, please contact our after-sales support system. Our engineers will reply to your email within one business day. (<https://support.anycubic.com/>)



After-sales support

Warm tips:

1. Fill in the information based on the SN of the corresponding model. Items marked with a red dot are required.
2. If the order is successful, you will soon receive a reply from the after-sales service system in your mailbox.
3. If you successfully place an order but do not receive an email, please check your spam/junk folder.
4. If the order creation fails, please pay attention to the pop-up reminder on the web page.

FCC Regulatory Compliance

WARNING: This device complies with part 15 of the FCC Rules.

Operation is subject to the following two conditions:

(1) This device may not cause harmful interference, and (2) this device must accept any interference received, including interference that may cause undesired operation.

Caution: the user that changes or modifications not expressly approved by the party responsible for compliance could void the user's authority to operate the equipment.

Note:

This equipment has been tested and found to comply with the limits for a Class B digital device, pursuant to part 15 of the FCC Rules. These limits are designed to provide reasonable protection against harmful interference in a residential installation. This equipment generates, uses and can radiate radio frequency energy and, if not installed and used in accordance with the instructions, may cause harmful interference to radio communications. However, there is no guarantee that interference will not occur in a particular installation. If this equipment does cause harmful interference to radio or television reception, which can be determined by turning the equipment off and on, the user is encouraged to try to correct the interference by one or more of the following measures:

- Reorient or relocate the receiving antenna.
- Increase the separation between the equipment and receiver.
- Connect the equipment into an outlet on a circuit different from that to which the receiver is connected.
- Consult the dealer or an experienced radio/TV technician for help.

To maintain compliance with FCC's RF Exposure guidelines. This equipment should be installed and operated with minimum distance between 20cm the radiator your body: Use only the supplied antenna.



Disposal of Electronic Components

This symbol indicates that the device must not be disposed of with household waste. When this product reaches the end of its life, please dispose of it in accordance with local environmental regulations. Take it to a collection point for the recycling of waste electrical and electronic equipment. Proper disposal helps prevent environmental and health hazards caused by inappropriate handling of electronic waste. Recycling also supports the conservation of natural resources. Do not dispose of this product with unsorted municipal waste.



Entsorgung elektronischer Bauteile

Dieses Symbol weist darauf hin, dass das Gerät nicht mit dem Haushaltsmüll entsorgt werden darf. Am Ende seiner Lebensdauer entsorgen Sie dieses Produkt bitte gemäß den örtlichen Umweltvorschriften. Bringen Sie es zu einem Sammelpunkt für das Recycling von Elektro- und Elektronik-Altgeräten. Eine ordnungsgemäße Entsorgung hilft, Umwelt- und Gesundheitsgefahren durch unsachgemäße Behandlung von Elektroschrott zu vermeiden. Recycling unterstützt auch den Erhalt natürlicher Ressourcen. Entsorgen Sie dieses Produkt nicht mit dem unsortierten Siedlungsabfall.



Élimination des composants électroniques

Ce symbole indique que l'appareil ne doit pas être jeté avec les déchets ménagers. Lorsque ce produit atteint la fin de sa vie, veuillez l'éliminer conformément aux réglementations environnementales locales. Apportez-le à un point de collecte pour le recyclage des déchets d'équipements électriques et électroniques. Une élimination correcte aide à prévenir les risques environnementaux et sanitaires causés par une manipulation inappropriée des déchets électroniques. Le recyclage soutient également la conservation des ressources naturelles. Ne jetez pas ce produit avec les déchets municipaux non triés.



Eliminación de componentes electrónicos

Este símbolo indica que el dispositivo no debe desecharse con los residuos domésticos. Al final de su vida útil, por favor, dispóngalo de acuerdo con las regulaciones ambientales locales. Llévelo a un punto de recogida para el reciclaje de residuos de aparatos eléctricos y electrónicos. Una eliminación adecuada ayuda a prevenir los peligros ambientales y para la salud causados por una manipulación inapropiada de los residuos electrónicos. El reciclaje también apoya la conservación de los recursos naturales. No deseches este producto con los residuos municipales sin clasificar.



Smaltimento dei componenti elettronici

Questo simbolo indica che il dispositivo non deve essere smaltito con i rifiuti domestici. Al termine del suo ciclo di vita, si prega di smaltirlo in conformità con le normative ambientali locali. Portalo a un punto di raccolta per il riciclaggio di apparecchiature elettriche ed elettroniche usate. Uno smaltimento corretto aiuta a prevenire i rischi ambientali e per la salute causati da una gestione inadeguata dei rifiuti elettronici. Il riciclaggio supporta anche la conservazione delle risorse naturali. Non smaltire questo prodotto con i rifiuti urbani non differenziati.



Name:Lienco SAS
 Add:8 Rue Marcel Cerdan, 77600, Bussy Saint Georges, France
 Contact:Ruoyu Zhang
 Tel:0033766929910
 E-Mail:contact@lienco.eu



Name:WSJ PRODUCT LTD
 Add:Unit 1, Alsop Arcade, Brownlow Hill, Liverpool L3 5TX
 Contact:Michael
 Tel:+44 1519470193
 E-Mail:info@wsj-product.com

ANYCUBIC
合格证

品名: FDM/LCD

检验员: 

出厂日期: _____

执行标准: GB4943.1

深圳市纵维立方科技有限公司
 地址:广东省深圳市龙岗区园山街道银荷社区
 银海工业城11号厂房



M02010203